





SPECIFICATIONS

CUSTOMER : _____
MODEL NO. : **GFC1602AE-YPOEJSB**
VERSION : **B**
DATE : **2016.12.14**
CERTIFICATION : **ROHS**
CUSTOMER SIGN : _____

QA Approved By	Approved By	Prepared By	Prepared By
			

晶發科技股份有限公司
GI FAR TECHNOLOGY CO.,LTD

新北市樹林區東豐街 81 號

No. 81, Dongfeng St, Shulin District, 23874, New Taipei City, Taiwan, R.O.C.

TEL: +886-2-8684-1188 FAX: +886-2-8684-8532



Revision Record

Data(y/m/d)	Ver.	Description	Note	page
2015.05.18	A	Specification released		
2016.12.14	B	修改公司抬頭、格式統一		



CONTENTS

1. Scope	-----	4
2. Product Specifications	-----	4
2.1 General	-----	4
2.2 Mechanical Characteristics	-----	4
2.3 Absolute Maximum Ratings	-----	5
2.4 Electrical Characteristics	-----	5
2.5 Optical Characteristics Absolute maximum ratings	-----	5
2.6 Optical Characteristics	-----	6
2.7 LED Back-light Characteristics	-----	7
3. Reliability	-----	8
4. Operating Instructions	-----	9
4.1 Input signal Function	-----	9
4.2 Voltage Generator Circuit	-----	9
4.3 Timing Diagram	-----	10
4.4 Display Command	-----	11
5. Character Pattern	-----	12
6. Notes	-----	13
7. Operation Precautions	-----	13
8. LCM Dimensions	-----	14



1. SCOPE

This specification covers the engineering requirements for the GFC1602AE-YPOEJSB liquid crystal module.

2. PRODUCT SPECIFICATIONS

2.1 General

- 16 × 2 dot matrix LCD
- STN(Y/G), Positive mode LCD panel
- Transflective , Wide temperature type
- 6 o'clock
- Multiplexing driving : 1/16duty, 1/5bias
- Controller IC : ST7066U-0A
- Backlight: Yellow Green

2.2 Mechanical Characteristics

Item	Value	Unit
Number of Characters	16X2	Character
Character Format	5X8 Dots	-
Character Pitch	4.82(W)X8.26(H)	mm
Character Size	4.07(W) X7.76(H)	mm
Dot size	0.75(W)X0.90(H)	mm
Dot pitch	0.83(W)X0.98(H)	mm
Module dimension	100 (W)X38.8(H)X12.2MAX(T)	mm
Active Area	76.73(W)X16.02(H)	mm
Viewing Area	80(W) X 20.4(H)	mm
Module	No Connector	



2.3 Absolute Maximum Ratings (Without LED back-light)

Characteristic	Symbol	Unit	Value
Operating Voltage (logic)	V_{DD}	V	-0.3 to +5.0
Input Voltage	V_{IN}	V	-0.3 to $V_{DD}+0.3$

Note 1: Referenced to $V_{SS}=0V$

2.4 Electrical Characteristics (Without LED back-light)

Characteristic	Symbol	Condition	Min.	Typ.	Max.	Unit
Operating Voltage(logic)	$V_{DD}-V_{SS}$	--	4.7	5.0	5.3	V
Input Voltage	V_{IH}	--	$0.8V_{DD}$	--	V_{DD}	V
	V_{IL}	--	V_{SS}	--	$0.2V_{DD}$	
Output Voltage	V_{OH}	$I_{OH}=-0.1mA$	$0.8V_{DD}$	--	V_{DD}	V
	V_{HL}	$I_{OL}=0.1mA$	V_{SS}	--	$0.2V_{DD}$	

2.5 Optical Characteristics Absolute maximum ratings

Item	Symbol	Rating	Unit
Operating temperature range	Top	-20~70	°C
Storage temperature range	Tst	-30~80	°C



2.6. Optical Characteristics

1/16 duty, 1/5 bias, Vop=4.5V, Ta=25°C

Item	Symbol	Conditions	Min.	Typ.	Max	Reference
Driving voltage	Vop=VDD-VO		--	4.5	--	
Viewing angle	$\theta 1$ 、 $\theta 2$	$C \geq 2.0, \phi = 0^\circ$ C	30°	-		Notes 1 & 2
Contrast	C	$\theta = 5^\circ, \phi = 0^\circ$	2.0	-	-	Note 3
Response time(rise)	ton	$\theta = 5^\circ, \phi = 0^\circ$	-	100ms	150ms	Note 4
Response time(fall)	toff	$\theta = 5^\circ, \phi = 0^\circ$	-	300ms	500ms	Note 4

Note 1: Definition of angles θ and ϕ

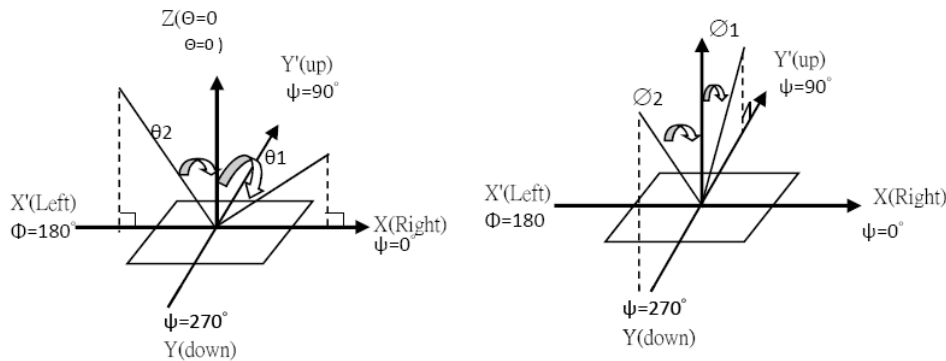

Note 2: Definition of viewing angles $\theta 1$ and $\theta 2$

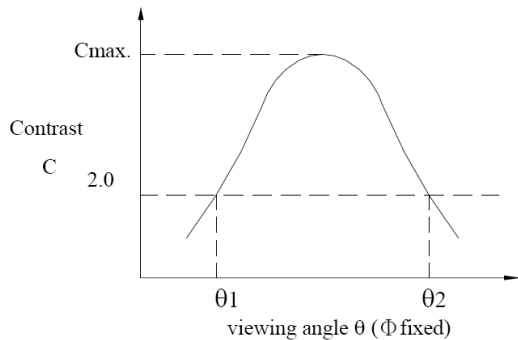

Note : Optimum viewing angle with the naked eye and viewing angle θ at Cmax. Above are not always the same

Note 3: Definition of contrast C

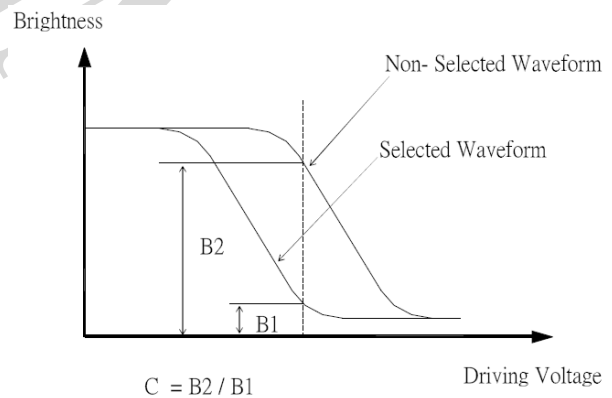

Note 4: Definition of response time

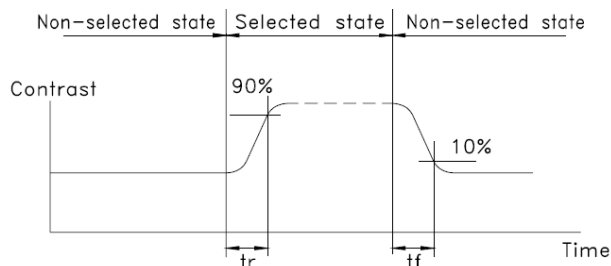

Note: Measured with a transmissive LCD panel which is displayed 1 cm²

V_{OPR} : Operating voltage f_{FRM} : Frame frequency
t_{ON} : Response time (rise) t_{OFF} : Response time (fall)



2.7 LED Back-light Characteristics

2.7.1 Electrical / optical specifications

Ta = 25°C

Item	Symbol	Condition	Min.	Typ.	Max.	Unit
Forward voltage	V_f	If=210mA, Yellow Green	3.9	4.1	4.3	V
*Luminous Intensity	I_v	If=210mA, Yellow Green	160	180	--	cd/m ²
Peak Emission Wavelength	λ_P	If=210mA, Yellow Green	570	572	574	nm
Spectrum Radiation Bandwidth	$\Delta\lambda$	If=210mA, Yellow Green	--	30	--	nm
Reverse Current	I_R	VR=10V, Yellow Green	--	--	0.21	mA
Luminous Uniformity	ΔL_v	If=210mA, Yellow Green	80			%

Note: * Measured at the bare LED back-light unit.

2.7.2 LED Maximum Operating Range

Item	Symbol	Yellow Green	Unit
Power Dissipation	P_{AD}	1350	mW
Forward Current	I_F	315	mA
Reverse Voltage	V_R	10	V



3. RELIABILITY

NO.	ITEM	CONDITION		STANDARD	NOTE
1	High Temp. Storage	80°C	120 hrs	Appearance Without defect	
2	Low Temp. Storage	-30°C	120 hrs	Appearance Without defect	
3	High Temp. & High Humi. Storage	40°C 90% RH	120 hrs	Appearance Without defect	
4	High Temp. Operating Display	70°C	120 hrs	Appearance Without defect	
5	Low Temp. Operating Display	-20°C	120 hrs	Appearance Without defect	
6	Thermal Shock	-20°C, 30min. → 70°C, 30min.  (1cycle)		Appearance Without defect	10 cycles

** Dissipation current, contrast and display functions

** Polarizing filter deterioration, other appearance defects

** The function test shall be conducted after 4hours storage at the normal temperature and humidity after remove from the test chamber.



4. OPERATING INSTRUCTIONS

4.1 Input signal Function

NO.	Symbol	Function
1	VSS	Ground (0V)
2	VDD	Power supply for Logic circuit
3	NC(V0)	NC
4	RS	Data / Instruction select
5	R/W	Read / Write select
6	E	Enable signal
7-14	DB0-DB7	Data Bus line
15	LED K	LED(-)
16	LEDA	LED(+5V)

4.2 Voltage Generator Circuit

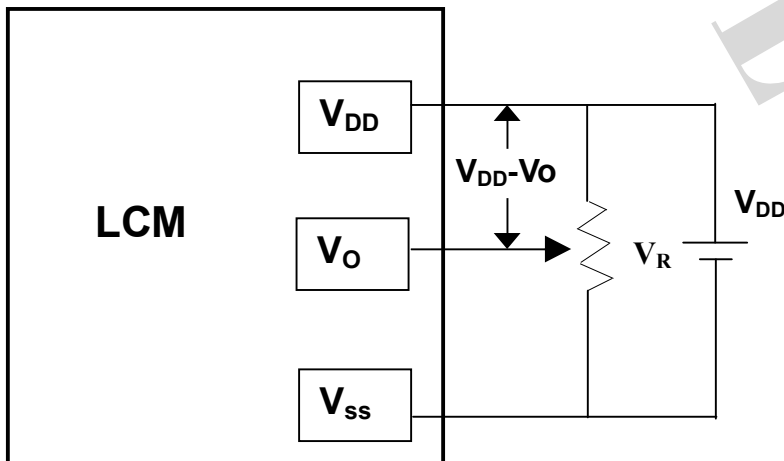

$V_{DD}-V_o$: LCD Driving Voltage
 V_R : 10K~20K



4.3 Timing Diagram

Mode	Characteristic	Symbol	Min.	Typ.	Max.	Unit
Write Mode	E Cycle Time	t_c	500	--	--	ns
	E Rise/fall Time	t_r, t_f	--	--	20	
	E Pulse Width (High,Low)	t_w	230	--	--	
	R/W and RS Setup Time	t_{su1}	40	--	--	
	R/W and RS Hold Time	t_{h2}	10	--	--	
	Data Setup Time	t_{su2}	80	--	--	
	Data Hold Time	t_{h2}	10	--	--	
Read Mode	E Cycle Time	t_c	500	--	--	ns
	E Rise/fall Time	t_r, t_f	--	--	20	
	E Pulse Width (High,Low)	t_w	230	--	--	
	R/W and RS Setup Time	t_{su}	40	--	--	
	R/W and RS Hold Time	t_h	10	--	--	
	Data Output Delay Time	t_D	--	--	120	
	Data Hold Time	t_{DH}	5	--	--	

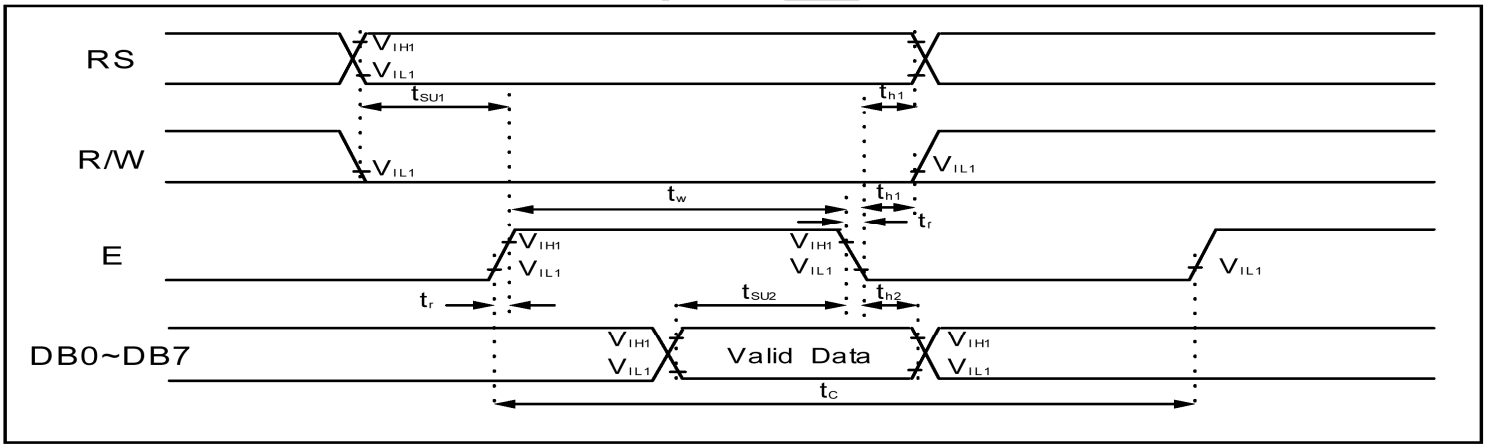

Write Mode Timing Diagram

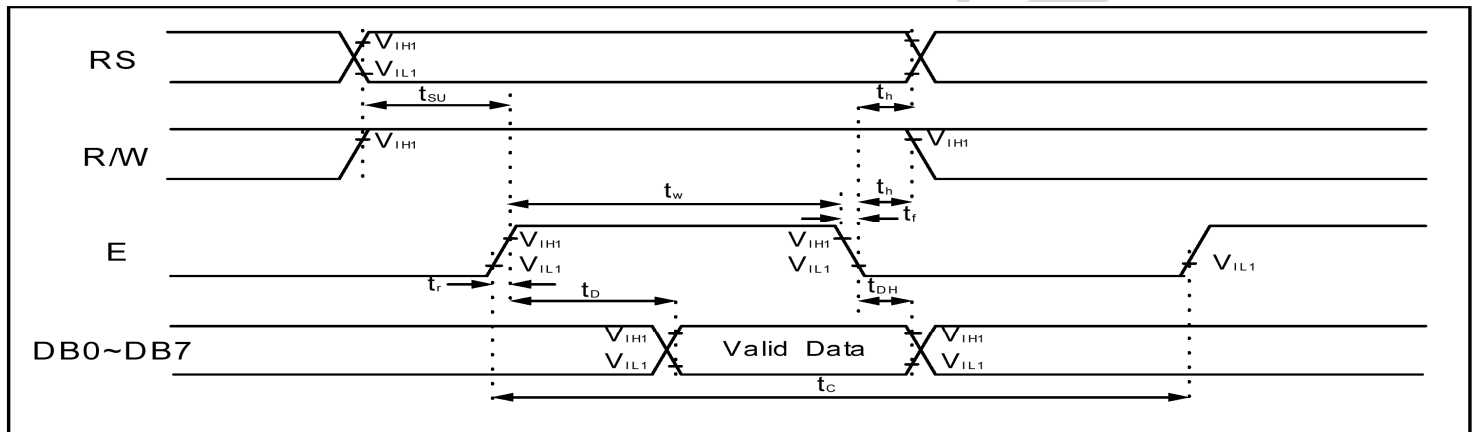

Read Mode Timing Diagram



4.4 Display Comman

Instructions	Instruction Code										Description	Execution Time (fosc = 270KHZ)
	RS	R/W	DB7	DB6	DB5	DB4	DB3	DB2	DB1	DB0		
Clear Display	0	0	0	0	0	0	0	0	0	1	Write "20H" to DDRAM. and set DDRAM address to "00H" from AC.	1.53ms
Return Home	0	0	0	0	0	0	0	0	1	*	Set DDRAM address to "00H" from AC and return cursor to it's original position if shifted. The contents of DDRAM are not changed.	1.53ms
Entry Mode Set	0	0	0	0	0	0	0	1	I/D	SH	Assign cursor moving direction and make shift of entire display enable.	39µs
Display ON/OFF Control	0	0	0	0	0	0	1	D	C	B	Sets display (D), cursor(C), and blinking of cursor(B) on/off control bit.	39µs
Cursor or Display Shift	0	0	0	0	0	1	S/C	R/L	*	*	Set cursor moving and display shift control bit, and the direction, without changing of DDRAM data.	39µs
Function Set	0	0	0	0	1	DL	N	F	*	*	Set interface data length (DL:4-bit/8-bit), numbers of display line (N: 1-line/2-line), display font type(F:5*8 dots/5*11 dots)	39µs
Set CGRAM Address	0	0	0	1	AC5	AC4	AC3	AC2	AC1	AC0	Set CGRAM address in address counter.	39µs
Set DDRAM Address	0	0	1	AC6	AC5	AC4	AC3	AC2	AC1	AC0	Set DDRAM address in address counter.	39µs
Read Busy Flag and Address	0	1	B F	AC6	AC5	AC4	AC3	AC2	AC1	AC0	Whether during internal operation or not can be known by reading BF. The contents of address counter can also be read.	0µs
Write Data to RAM	1	0	D 7	D6	D5	D4	D3	D2	D1	D0	Write data into internal RAM (DDRAM/CGRAM).	43µs
Read Data from RAM	1	1	D 7	D6	D5	D4	D3	D2	D1	D0	Read data from internal RAM (DDRAM/CGRAM).	43µs

※ "x":don't care



5. Character Pattern

NO.7066-0A

b7-b4 b3-b0	0000	0001	0010	0011	0100	0101	0110	0111	1000	1001	1010	1011	1100	1101	1110	1111
0000	CG RAM (1)			0	0P	P	P				-	9	E	O	P	
0001	(2)		!	1	A	a	a				.	7	7	4	8	q
0010	(3)		"	2	B	R	r				7	4	9	X	P	0
0011	(4)		#	3	C	S	s				J	9	7	E	E	*
0100	(5)		\$	4	D	T	t				V	I	T	P	W	Q
0101	(6)		%	5	E	U	u				*	7	6	1	0	0
0110	(7)		&	6	F	V	v				7	0	2	3	P	Z
0111	(8)		'	7	G	W	w				7	*	X	7	g	π
1000	(1)		(8	H	X	x				4	0	*	U	r	X
1001	(2))	9	I	Y	y				0	7	J	W	'	Y
1010	(3)		*	:	J	Z	z				2	0	n	V	J	7
1011	(4)		+	;	K	L	l				*	7	E	0	*	A
1100	(5)		,	<	L	*	l				0	9	7	7	0	π
1101	(6)		-	=	M	I	i				2	X	\	U	L	+
1110	(7)		.	>	N	^	n				3	E	0	*	n	
1111	(8)		/	?	O	_	o				0	U	7	"	0	■



6. NOTES

▪ Safety

- If the LCD panel breaks, be careful not to get the liquid crystal in your mouth. If the liquid crystal touches your skin or clothes, wash it off immediately using soap and plenty of water.

Handling

- Avoid static electricity as this can damage the CMOS LSI.
- The LCD panel is plate glass; do not hit or crush it.
- Do not remove the panel or frame from the module.
- The polarizing plate of the display is very fragile; handle it very carefully

Mounting and Design

- Mount the module by using the specified mounting part and holes.
- To protect the module from external pressure, leave a small gap by placing transparent plates (e.g. acrylic or glass) on the display surface, frame, and polarizing plate
- Design the system so that no input signal is given unless the power-supply voltage is applied.
- Keep the module dry. Avoid condensation, otherwise the transparent electrodes may break.

Storage

- Store the module in a dark place where the temperature is $25^{\circ}\text{C} \pm 10^{\circ}\text{C}$ and the humidity below 65% RH.
- Do not store the module near organic solvents or corrosive gases.
- Do not crush, shake, or jolt the module (including accessories).

Cleaning

- Do not wipe the polarizing plate with a dry cloth, as it may scratch the surface.
- Wipe the module gently with soft cloth soaked with a petroleum benzine.
- Do not use ketonic solvents (ketone and acetone) or aromatic solvents (toluene and xylene), as they may damage the polarizing plate.

7. OPERATION PRECAUTIONS

Any changes that need to be made in this specification or any problems arising from it will be dealt with quickly by discussion between both companies.



8. LCM Dimension

